

COD. 500002979 REV.7

ACERBIS PARTS	O.E.M ITEMS TO USE:
A1 - L13,5 (1 pcs.)	G
A2 - L18 (1 pcs.)	H
B - (2 pcs.)	I
C1 - M6X25 (1 pcs.)	D - M6x40 (2 pcs.)
C2 - M6X30 (1 pcs.)	T
E - (2 pcs.)	
F - M6X10 (2 pcs.)	
L - L29 (2 pcs.)	
M - M6X20 (7 pcs.)	
N - (1 pcs.)	
O - M6 (6 pcs.)	
P - M5X14 (1 pcs.)	
Q+R (1 + 1 pcs.)	
S - L3 (6 pcs.)	

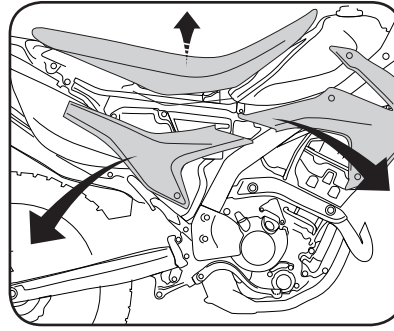

1. Smontare la sella e le plastiche
Remove the seat and plastics

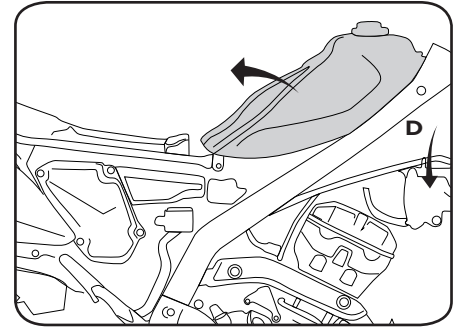

2. Smontare serbatoio originale: le due viti D che fissano il serbatoio verranno usate per rimontare gli spoiler.
Remove the original tank: two screws D that fix the tank, will be used for fix the radiator scoops.

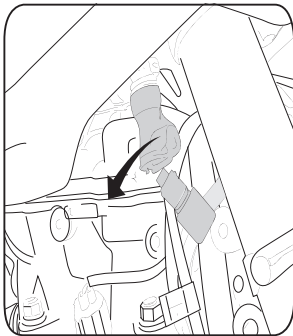

3. Scollegare connessioni pompa del serbatoio
Disconnect the pump tank connections

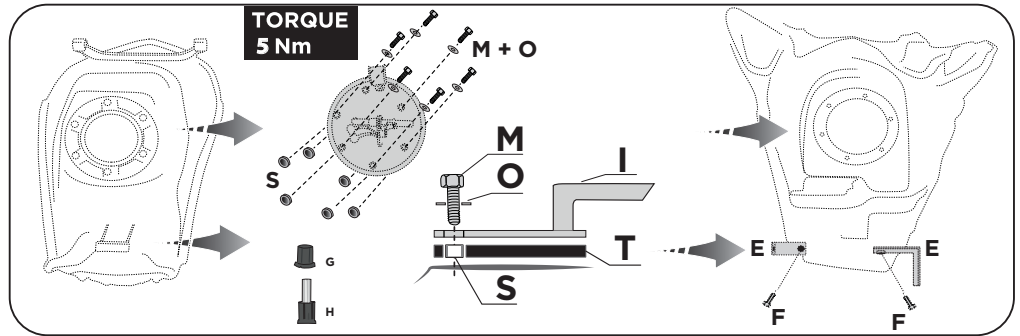

4. Smontare il gommino G+H e la pompa dal serbatoio originale e rimontarli sul serbatoio Acerbis, interponendo le bussole S fra serbatoio ed il gruppo pompa e utilizzando le viti M e le rondelle O. **ATTENZIONE:** sostituire la guarnizione T usata, con una nuova originale Honda. Montare le staffe E tramite le viti F.
Remove the G+H rubber and the pump from the original tank and reassemble it on the Acerbis tank, put the S bushes between the tank and the pump unit by the M screws and O washers. ATTENTION: replace T gasket used, with a new original gasket Honda. Fix on the tank the brackets E by the screws F.

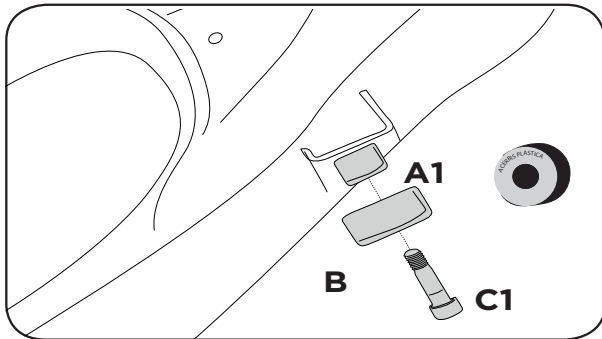

5. Montare supporti serbatoio DX (il gommino B deve essere montato con le scritte "ACERBIS" lato in vista).
Mount all the brackets Rh on the frame (the B rubber must be fix with the "ACERBIS PLASTICA" outside)

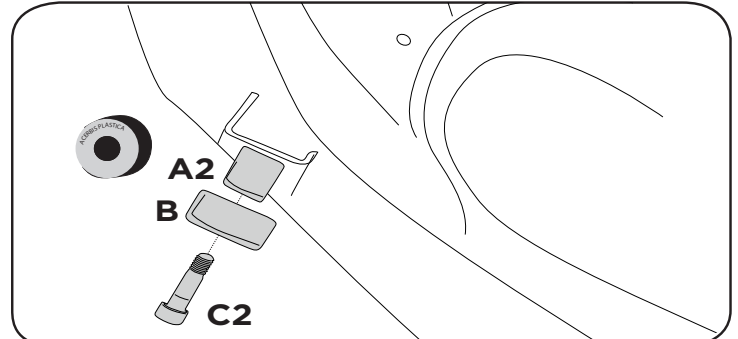

6. Montare supporti serbatoio SX (il gommino B deve essere montato con le scritte "ACERBIS" lato in vista).
Mount all the brackets Lh on the frame (the B rubber must be fix with the "ACERBIS PLASTICA" outside)

WARNING!

Clean tank interior thoroughly before installation. install this fuel tank only in a well ventilated area, as gasoline fumes are extremely dangerous. do not start operate the vehicle if there are any fuel leaks! acerbis recommends that installation be done by licensed mechanic. read all instructions first before beginning installation.

ATTENZIONE!

pulire a fondo l'interno del serbatoio prima dell'installazione. svolgere l'operazione unicamente in un ambiente ventilato, poiche' i fumi della benzina sono estremamente pericolosi. non avviare il veicolo se si riscontrano perdite di carburante! acerbis raccomanda l'installazione presso meccanici autorizzati. leggere attentamente le istruzioni prima di iniziare il montaggio.

DISCLAIMER:

DISCLAIMER: Due to uncontrolled variables in the manufacturing process of rotationally molded fuel tanks, the fuel tank may vary in size and shape by up 7% of the manufacturer's original listed capacity.

LIBERATORIA

LIBERATORIA: A causa di variabili inponderabili nel processo di stampaggio rotazionale dei serbatoi, questi possono differire in forma e dimensioni fino al 7% rispetto alla capacita' dichiarata.

**FOR COMPETITION USE ONLY
SOLO PER USO AGONISTICO**

COD. 500002979 REV.7

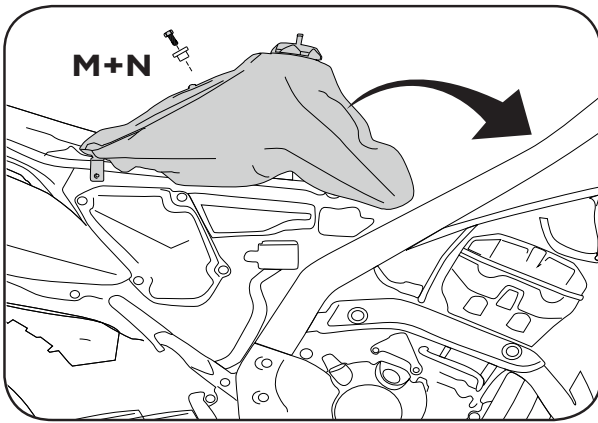

- 7.** Fissare sul serbatoio Acerbis la boccola sella N tramite la vite M e montarlo sulla moto.
Fix the seat bush N by the screw M and Mount Acerbis tank on the bike.

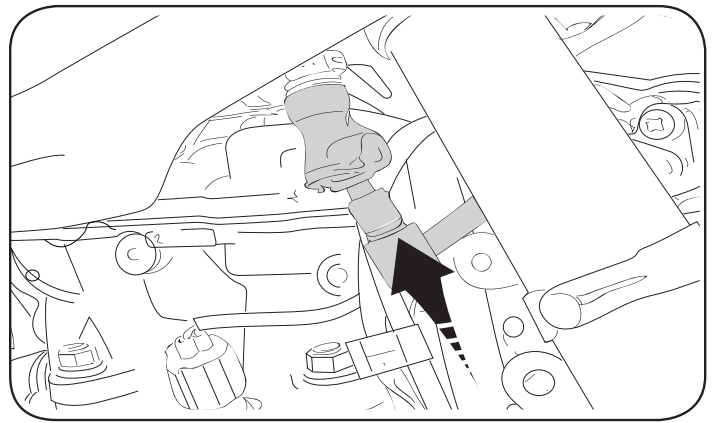

- 8.** Ricollegare connessioni pompa serbatoio.
Reconnect the pump tank

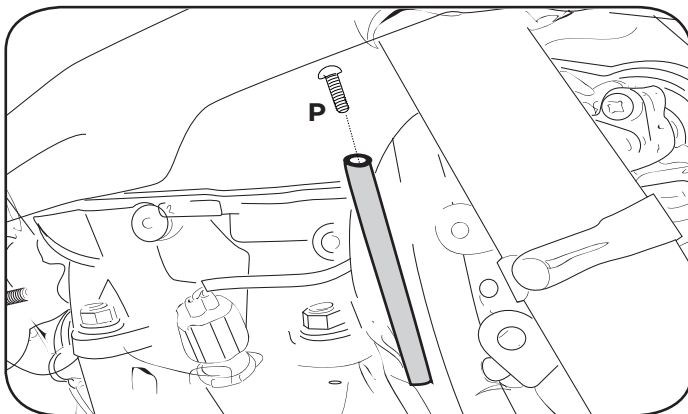

- 9.** Inserire la vite P nel tubo di scarico benzina del serbatoio.
Put the screw P on drainage pipe of gasoline.

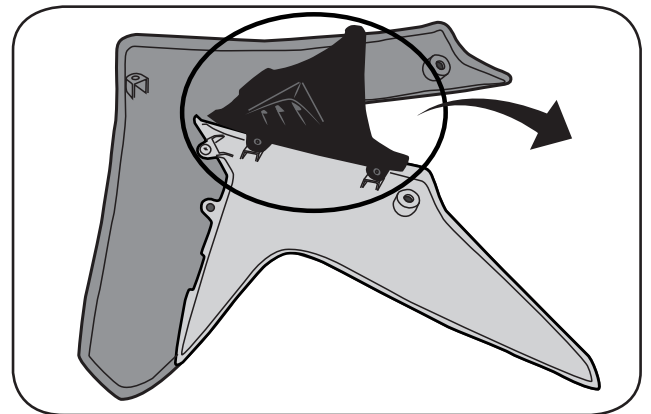

- 10.** Rimuovere la piccola cover interna paletta del fianchetto radiatore destro.
Remove the internal cover from the right radiator scoop.

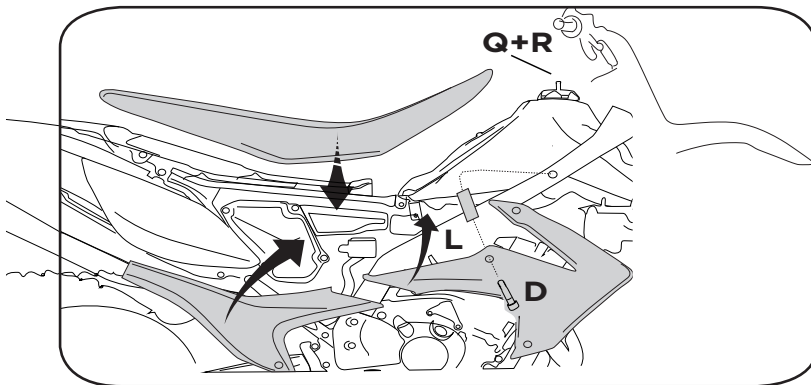

- 11.** Rimontare plastiche moto e sella. Utilizzare la vite D e la bussola L per il fissaggio al foro centrale dello spoiler. Fissare il tubo benzina Q al tappo serbatoio e al manubrio tramite lo sfianto R.
Mount plastics and the seat. Use the screws D and the bush L for fix the central hole of the radiator scoops. Fix the Q Pipe on the cup and on handlebar by the R plastic bracket .

WARNING!

Clean tank interior thoroughly before installation. install this fuel tank only in a well ventilated area, as gasoline fumes are extremely dangerous. do not start operate the vehicle if there are any fuel leaks! acerbis recommends that installation be done by licensed mechanic. read all instructions first before beginning installation.

ATTENZIONE!

pulire a fondo l'interno del serbatoio prima dell'installazione. svolgere l'operazione unicamente in un ambiente ventilato, poiche' i fumi della benzina sono estremamente pericolosi. non avviare il veicolo se si riscontrano perdite di carburante! acerbis raccomanda l'installazione presso meccanici autorizzati. leggere attentamente le istruzioni prima di iniziare il montaggio.

DISCLAIMER:

DISCLAIMER: Due to uncontrolled variables in the manufacturing process of rotationally molded fuel tanks, the fuel tank may vary in size and shape by up 7% of the manufacturer's original listed capacity.

LIBERATORIA

LIBERATORIA: A causa di variabili inponderabili nel processo di stampaggio rotazionale dei serbatoi, questi possono differire in forma e dimensioni fino al 7% rispetto alla capacita' dichiarata.

**FOR COMPETITION USE ONLY
 SOLO PER USO AGONISTICO**

ACERBIS®

Thank you for purchasing an ACERBIS fuel tank

WARNING

It is **EXTREMELY IMPORTANT** that the fuel tank be properly installed. To ensure proper installation, it is **STRONGLY RECOMMENDED** that the tank be installed only by a qualified OEM licensed dealership mechanic. Improper installation could result in serious injury or even death.

If self-installed NOTE THE FOLLOWING. Particular attention must be paid to excessive fuel line length and fuel line proximity to hot engine areas and pipes to prevent fire.

Clean tank interior thoroughly before installation. Install this fuel tank only in a well ventilated area, as gasoline fumes are extremely dangerous. Do not start or operate the vehicle if there are any fuel leaks! Read all instruction first before beginning installation.

DISCLAIMER

Due to uncontrolled variables in the manufacturing process of rotationally molded fuel tanks, the fuel tank may vary in size and shape by up to 7% of the manufacturer's original listed capacity.